

FLC091WF

C-Band Power GaAs FETs

ABSOLUTE MAXIMUM RATINGS (Ambient Temperature $T_a = 25^\circ\text{C}$)

Item	Symbol	Condition	Rating	Unit
Drain-Source Voltage	V_{DS}		+15	V
Gate-Source Voltage	V_{GS}		-5	V
Total Power Dissipation	P_T	$T_c=25^\circ\text{C}$	4.16	W
Storage Temperature	T_{stg}		-65 to +175	$^\circ\text{C}$
Channel Temperature	T_{ch}		175	$^\circ\text{C}$

Fujitsu recommends the following conditions for the reliable operation of GaAs FETs:

1. The drain - source operating voltage (V_{DS}) should not exceed +10 volts.
2. The forward and reverse gate currents should not exceed +1.0 and -0.5 mA respectively with gate resistance of 400Ω .

ELECTRICAL CHARACTERISTICS (Ambient Temperature $T_a = 25^\circ\text{C}$)

Item	Symbol	Test Conditions	Limit			Unit
			Min.	Typ.	Max.	
Saturated Drain Current	I_{DSS}	$V_{DS} = 5V, V_{GS} = 0V$	-	300	450	mA
Transconductance	g_m	$V_{DS} = 5V, I_{DS} = 200\text{mA}$	-	150	-	mS
Pinch-off Voltage	V_P	$V_{DS} = 5V, I_{DS} = 15\text{mA}$	-1.0	-2.0	-3.5	V
Gate-Source Breakdown Voltage	V_{GSO}	$I_{GS} = -15\mu\text{A}$	-5	-	-	V
Output Power at 1dB G.C.P.	P_{1dB}	$V_{DS} = 10V,$ $I_{DS} = 0.6 I_{DSS} (\text{Typ.}),$ $f = 6 \text{ GHz}$	27.5	28.8	-	dBm
Power Gain at 1dB G.C.P.	G_{1dB}		7.5	8.5	-	dB
Power added Efficiency	η_{add}		-	35	-	%
Thermal Resistance	R_{th}	Channel to Case	-	25	36	$^\circ\text{C/W}$

CASE STYLE: WF

G.C.P.: Gain Compression Point

POWER DERATING CURVE

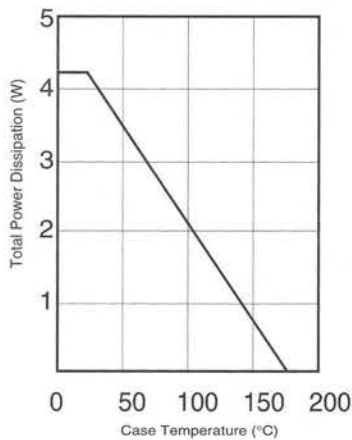

DRAIN CURRENT vs. DRAIN-SOURCE VOLTAGE

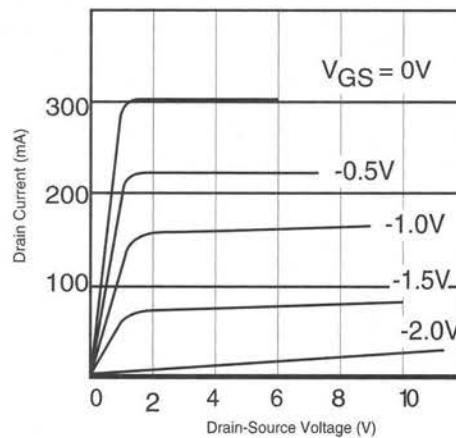

OUTPUT POWER & IM_3 vs INPUT POWER

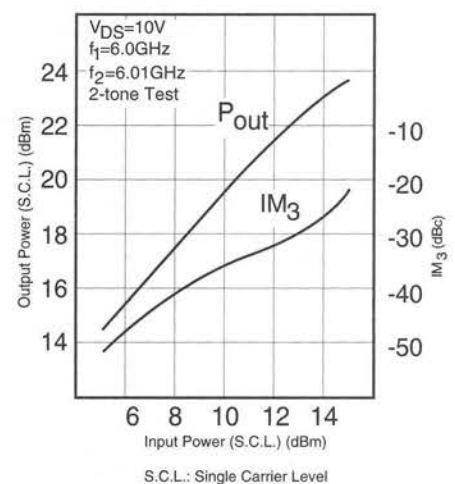

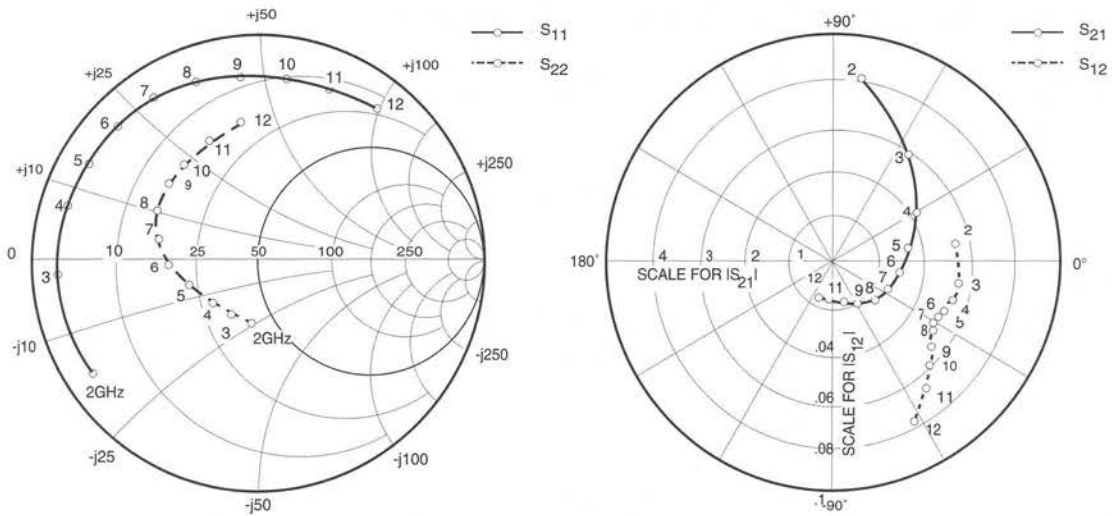

S-PARAMETERS
 $V_{DS} = +10V, I_{DS} = 180mA$

FREQUENCY (MHz)	S ₁₁		S ₂₁		S ₁₂		S ₂₂	
	MAG	ANG	MAG	ANG	MAG	ANG	MAG	ANG
500	.917	-58.1	8.230	142.7	.029	53.9	.342	-37.2
2000	.858	-148.7	4.080	78.2	.055	7.8	.264	-99.6
3000	.846	-175.8	2.860	52.8	.056	-6.6	.280	-123.5
4000	.840	164.0	2.163	30.5	.053	-16.3	.317	-144.6
5000	.841	148.2	1.730	10.8	.050	-23.7	.367	-162.7
6000	.850	134.3	1.440	-7.7	.048	-27.7	.425	-178.7
7000	.853	122.0	1.237	-24.9	.048	-31.6	.479	167.8
8000	.855	109.7	1.094	-42.3	.049	-34.2	.531	155.1
9000	.845	96.4	.972	-59.8	.053	-40.0	.570	141.9
10000	.839	82.5	.883	-76.8	.058	-46.1	.593	128.2
11000	.843	68.4	.823	-93.6	.065	-53.9	.621	114.9
12000	.849	52.5	.789	-111.8	.075	-63.2	.645	101.3

OUTPUT POWER vs. INPUT POWER

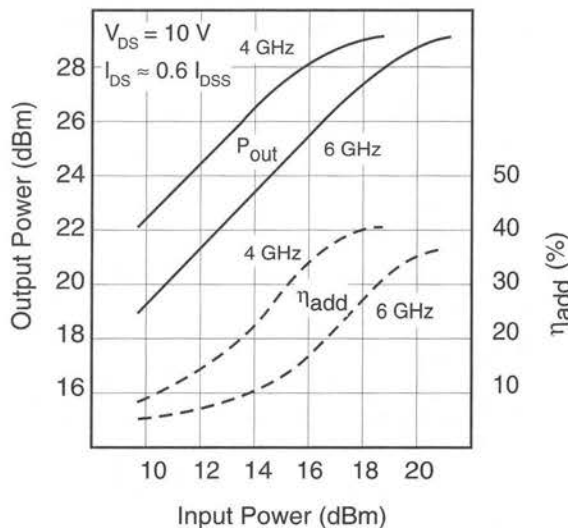

P_{1dB} & η_{add} vs. V_{DS}

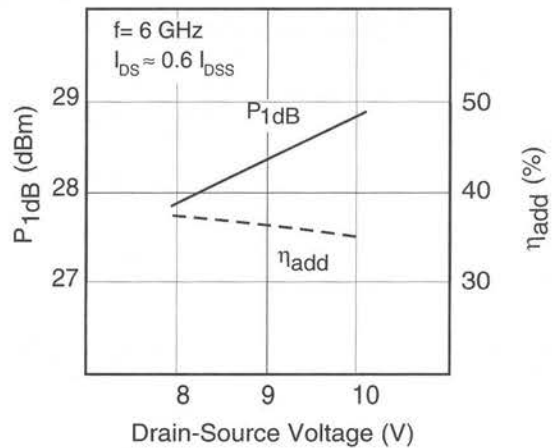

Case Style "WF" Metal-Ceramic Hermetic Package

