

Silicon RF Switching Diode

BA 582

- For low-loss VHF band switching in TV/VTR tuners

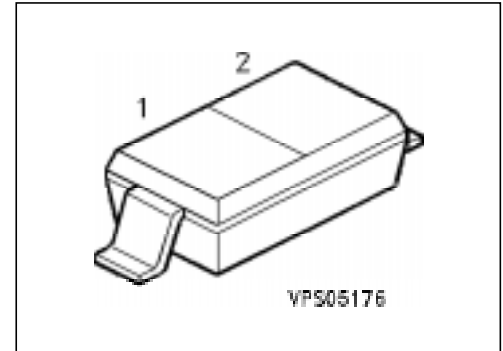

Type	Marking	Ordering Code	Pin Configuration	Package ¹⁾
BA 582	blue S	Q62702-A829		SOD-123

Maximum Ratings

Parameter	Symbol	Values	Unit
Reverse voltage	V_R	35	V
Forward current, $T_A \leq 60\text{ °C}$	I_F	100	mA
Operation temperature range	T_{op}	- 55 ... + 125	°C
Storage temperature range	T_{stg}	- 55 ... + 150	

Thermal Resistance

Junction - ambient	$R_{th,JA}$	≤ 600	K/W
--------------------	-------------	------------	-----

¹⁾ For detailed information see chapter Package Outlines.

Electrical Characteristics

at $T_A = 25\text{ }^\circ\text{C}$, unless otherwise specified.

Parameter	Symbol	Values			Unit
		min.	typ.	max.	
Forward voltage $I_F = 100\text{ mA}$	V_F	–	–	1	V
Reverse current $V_R = 20\text{ V}$	I_R	–	–	20	nA
Diode capacitance $f = 1\text{ MHz}$ $V_R = 1\text{ V}$ $V_R = 3\text{ V}$	C_T	– 0.6	0.92 0.85	1.4 1.1	pF
Forward resistance $f = 100\text{ MHz}$ $I_F = 3\text{ mA}$ $I_F = 10\text{ mA}$	r_f	– –	0.45 0.38	0.7 0.5	Ω
Reverse resistance $V_R = 1\text{ V}, f = 100\text{ MHz}$	$1/g_p$	–	100	–	k Ω
Series inductance	L_s	–	2.8	–	nH

Diode capacitance $C_T = f(V_R)$
 $f = 1\text{ MHz}$

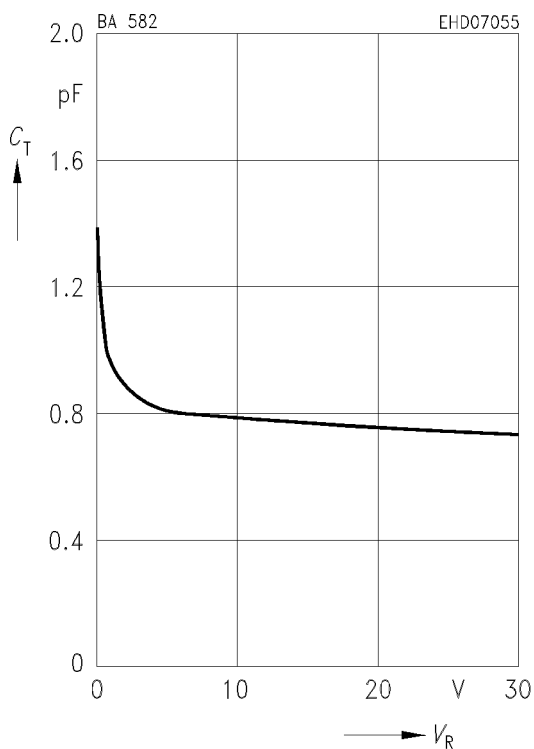

Forward resistance $r_f = f(I_F)$
 $f = 100\text{ MHz}$

