

Datasheet

- * Power amplifier for mobile phones
- * For frequencies up to 3 GHz
- * Operating voltage range: 2 to 6 V
- * P_{OUT} at $V_D=3V$, $f=1.8GHz$ typ. 23.5 dBm
- * High efficiency better 55 %

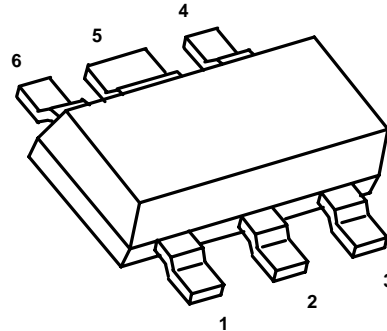

ESD: Electrostatic discharge sensitive device, observe handling precautions!

| Type | Marking | Ordering code (taped) | Pin Configuration | | | | | | Package 1) |
|-------|---------|--------------------------|-------------------|---|---|---|---|---|------------|
| | | | 1 | 2 | 3 | 4 | 5 | 6 | |
| CLY 2 | Y2 | Q62702-L96 | G | S | D | D | S | G | MW 6 |

| Maximum ratings | Symbol | | Unit |
|---|-----------|------------|------|
| Drain-source voltage | V_{DS} | 9 | V |
| Drain-gate voltage | V_{DG} | 12 | V |
| Gate-source voltage | V_{GS} | -6 | V |
| Drain current | I_D | 600 | mA |
| Channel temperature | T_{Ch} | 150 | °C |
| Storage temperature | T_{stg} | -55...+150 | °C |
| Total power dissipation ($T_S \leq 50^\circ C$) ²⁾ | P_{tot} | 900 | mW |

Thermal Resistance

| | | | |
|---------------------------------------|-------------|------------|-----|
| Channel-soldering point ²⁾ | R_{thChS} | ≤ 110 | K/W |
|---------------------------------------|-------------|------------|-----|

1) Dimensions see chapter Package Outlines

2) T_S is measured on the source lead at the soldering point to the pcb.

Electrical characteristics ($T_A = 25^\circ\text{C}$, unless otherwise specified)

| Characteristics | Symbol | min | typ | max | Unit |
|--|-------------|------|------|------|---------------|
| Drain-source saturation current $V_{DS} = 3\text{ V}$ $V_{GS} = 0\text{ V}$ | I_{DSS} | 300 | 450 | 650 | mA |
| Drain-source pinch-off current $V_{DS} = 3\text{ V}$ $V_{GS} = -3.8\text{ V}$ | $I_{D(p)}$ | - | 5 | 50 | μA |
| Gate pinch-off current $V_{DS} = 3\text{ V}$ $V_{GS} = -3.8\text{ V}$ | $I_{G(p)}$ | - | 5 | 20 | μA |
| Pinch-off Voltage $V_{DS} = 3\text{ V}$ $I_D = 50\text{ }\mu\text{A}$ | $V_{GS(p)}$ | -3.8 | -2.8 | -1.8 | V |
| Small Signal Gain ⁾ $V_{DS} = 3\text{ V}$ $I_D = 180\text{ mA}$ $f = 1.8\text{ GHz}$ $P_{in} = -5\text{ dBm}$ | G | - | 15.5 | - | dB |
| Small Signal Gain ^{**)} $V_{DS} = 3\text{ V}$ $I_D = 180\text{ mA}$ $f = 1.8\text{ GHz}$ $P_{in} = -5\text{ dBm}$ | G | - | 14.5 | - | dB |
| Output Power $V_{DS} = 3\text{ V}$ $I_D = 180\text{ mA}$ $f = 1.8\text{ GHz}$ $P_{in} = 10\text{ dBm}$ | P_O | 22.5 | 23.5 | | dBm |
| 1dB-Compression Point $V_{DS} = 3\text{ V}$ $I_D = 180\text{ mA}$ $f = 1.8\text{ GHz}$ | P_{1dB} | - | 23.5 | - | dBm |
| 1dB-Compression Point $V_{DS} = 5\text{ V}$ $I_D = 180\text{ mA}$ $f = 1.8\text{ GHz}$ | P_{1dB} | - | 27.0 | - | dBm |
| Power Added Efficiency $V_{DS} = 3\text{ V}$ $I_D = 180\text{ mA}$ $f = 1.8\text{ GHz}$ $P_{in} = 10\text{ dBm}$ | PAE | - | 55 | - | % |

⁾ Matching conditions for maximum small signal gain (not identical with power matching conditions !)

^{**)} Power matching conditions: $f = 1.8\text{ GHz}$

Source Match: Γ_{ms} : MAG = 0.74, ANG 132°; Load Match: Γ_{ml} : ;MAG 0.61, ANG -153°

Output Characteristics

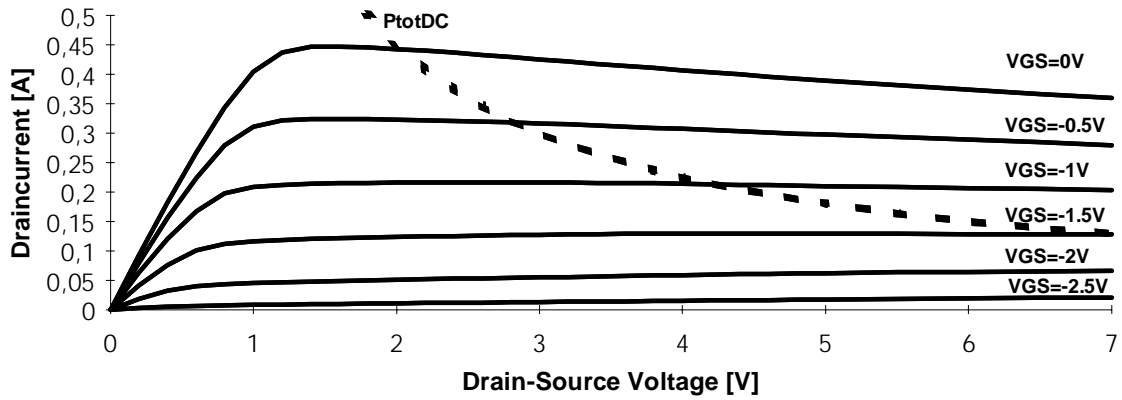

Compression Power vs. Drain-Source Voltage

$f = 1.8\text{GHz}; I_D = 0.5I_{DSS}$

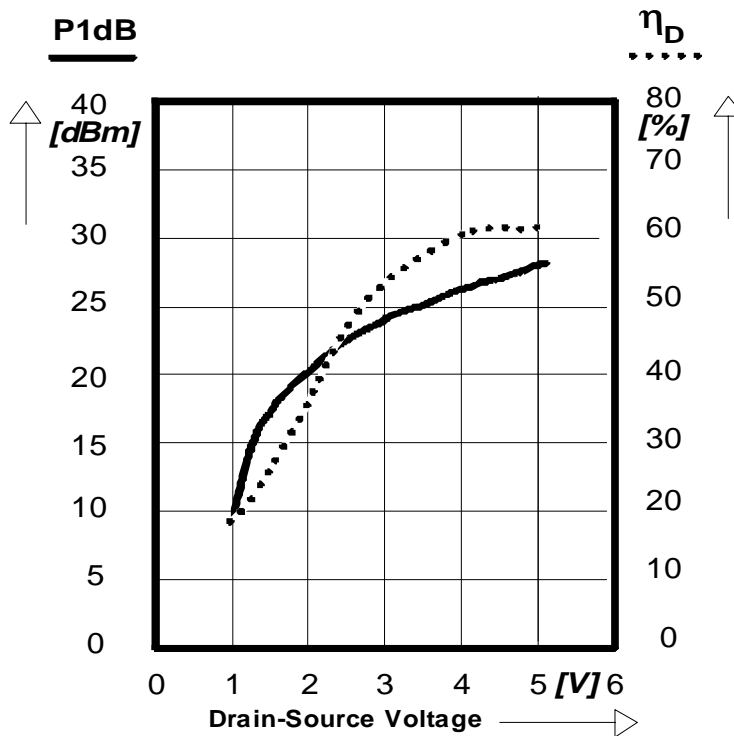

typ. Common Source S-Parameters
 $V_{DS} = 3 \text{ V}$ $I_D = 180 \text{ mA}$ $Z_0 = 50 \Omega$

| f GHZ | S11 | | S21 | | S12 | | S22 | |
|-------|------|--------|------|-------|-------|------|------|--------|
| | MAG | ANG | MAG | ANG | MAG | ANG | MAG | ANG |
| 0.100 | 0.99 | -12.0 | 9.17 | 171.6 | 0.007 | 83.3 | 0.15 | -16.6 |
| 0.150 | 0.99 | -17.9 | 9.11 | 167.4 | 0.011 | 80.8 | 0.16 | -24.2 |
| 0.200 | 0.98 | -23.7 | 9.01 | 163.4 | 0.014 | 77.6 | 0.16 | -31.2 |
| 0.250 | 0.97 | -29.5 | 8.89 | 159.3 | 0.017 | 74.7 | 0.16 | -39.0 |
| 0.300 | 0.96 | -35.1 | 8.75 | 155.4 | 0.021 | 72.4 | 0.16 | -45.9 |
| 0.400 | 0.94 | -46.0 | 8.40 | 147.8 | 0.026 | 67.0 | 0.17 | -58.2 |
| 0.500 | 0.92 | -56.4 | 8.03 | 140.7 | 0.031 | 62.5 | 0.18 | -69.2 |
| 0.600 | 0.89 | -66.2 | 7.61 | 134.1 | 0.036 | 58.0 | 0.18 | -79.0 |
| 0.700 | 0.86 | -75.4 | 7.22 | 128.0 | 0.039 | 54.4 | 0.19 | -87.0 |
| 0.800 | 0.84 | -84.1 | 6.82 | 122.3 | 0.043 | 51.2 | 0.20 | -94.2 |
| 0.900 | 0.82 | -92.1 | 6.45 | 117.2 | 0.045 | 48.3 | 0.20 | -100.4 |
| 1.000 | 0.80 | -99.7 | 6.10 | 112.3 | 0.048 | 46.1 | 0.21 | -105.3 |
| 1.200 | 0.77 | -113.6 | 5.45 | 103.6 | 0.052 | 41.8 | 0.22 | -115.1 |
| 1.400 | 0.74 | -125.9 | 4.92 | 95.8 | 0.055 | 38.6 | 0.23 | -122.9 |
| 1.500 | 0.73 | -131.5 | 4.71 | 92.1 | 0.056 | 37.2 | 0.23 | -125.7 |
| 1.600 | 0.72 | -137.1 | 4.48 | 88.5 | 0.057 | 36.2 | 0.24 | -129.4 |
| 1.800 | 0.72 | -147.4 | 4.10 | 81.7 | 0.059 | 34.0 | 0.25 | -135.0 |
| 2.000 | 0.71 | -157.2 | 3.77 | 75.0 | 0.060 | 31.9 | 0.26 | -139.7 |
| 2.200 | 0.71 | -165.3 | 3.47 | 68.8 | 0.062 | 31.2 | 0.27 | -143.0 |
| 2.400 | 0.71 | -173.3 | 3.19 | 63.0 | 0.063 | 29.7 | 0.29 | -147.2 |
| 2.500 | 0.71 | -177.4 | 3.06 | 60.1 | 0.063 | 28.9 | 0.29 | -150.0 |
| 3.000 | 0.72 | 165.7 | 2.52 | 47.2 | 0.065 | 28.4 | 0.32 | -159.7 |
| 3.500 | 0.74 | 151.7 | 2.12 | 36.4 | 0.066 | 29.7 | 0.36 | -167.5 |
| 4.000 | 0.76 | 139.9 | 1.85 | 26.5 | 0.073 | 30.6 | 0.39 | -173.1 |
| 4.500 | 0.78 | 127.4 | 1.61 | 15.3 | 0.078 | 28.2 | 0.42 | 179.2 |
| 5.000 | 0.79 | 116.7 | 1.43 | 4.6 | 0.085 | 24.0 | 0.45 | 174.3 |
| 5.500 | 0.80 | 106.3 | 1.23 | -5.9 | 0.085 | 20.9 | 0.49 | 167.8 |
| 6.000 | 0.83 | 97.1 | 1.06 | -14.8 | 0.087 | 17.7 | 0.52 | 160.9 |

Additional S-Parameter available on CD

typ. Common Source S-Parameters
 $V_{DS} = 5\text{ V}$ $I_D = 180\text{ mA}$ $Z_0 = 50\ \Omega$

| f GHz | S11 | | S21 | | S12 | | S22 | |
|-------|------|--------|------|-------|-------|------|------|--------|
| | MAG | ANG | MAG | ANG | MAG | ANG | MAG | ANG |
| 0.100 | 0.99 | -12.3 | 9.30 | 171.3 | 0.007 | 83.1 | 0.27 | -10.8 |
| 0.150 | 0.99 | -18.4 | 9.23 | 166.9 | 0.010 | 80.0 | 0.27 | -15.8 |
| 0.200 | 0.98 | -24.3 | 9.13 | 162.8 | 0.014 | 77.2 | 0.26 | -20.4 |
| 0.250 | 0.97 | -30.3 | 9.00 | 158.5 | 0.017 | 73.6 | 0.26 | -25.7 |
| 0.300 | 0.96 | -36.1 | 8.85 | 154.6 | 0.020 | 71.1 | 0.26 | -30.5 |
| 0.400 | 0.94 | -47.2 | 8.48 | 146.7 | 0.026 | 65.8 | 0.26 | -39.2 |
| 0.500 | 0.91 | -57.8 | 8.08 | 139.4 | 0.030 | 61.0 | 0.25 | -47.7 |
| 0.600 | 0.89 | -67.8 | 7.64 | 132.6 | 0.034 | 56.3 | 0.25 | -55.4 |
| 0.700 | 0.86 | -77.1 | 7.23 | 126.3 | 0.038 | 52.8 | 0.25 | -62.2 |
| 0.800 | 0.84 | -85.9 | 6.81 | 120.6 | 0.041 | 49.5 | 0.24 | -68.6 |
| 0.900 | 0.81 | -93.9 | 6.43 | 115.3 | 0.043 | 46.4 | 0.24 | -74.1 |
| 1.000 | 0.80 | -101.5 | 6.07 | 110.4 | 0.045 | 44.2 | 0.24 | -79.2 |
| 1.200 | 0.76 | -115.4 | 5.40 | 101.4 | 0.048 | 40.1 | 0.24 | -88.8 |
| 1.400 | 0.74 | -127.6 | 4.87 | 93.6 | 0.051 | 36.9 | 0.24 | -96.8 |
| 1.500 | 0.73 | -133.2 | 4.65 | 89.8 | 0.052 | 35.6 | 0.24 | -100.2 |
| 1.600 | 0.72 | -138.8 | 4.42 | 86.1 | 0.052 | 34.6 | 0.24 | -103.9 |
| 1.800 | 0.72 | -149.0 | 4.04 | 79.2 | 0.054 | 32.7 | 0.25 | -110.4 |
| 2.000 | 0.71 | -158.6 | 3.71 | 72.3 | 0.054 | 30.9 | 0.26 | -116.2 |
| 2.200 | 0.71 | -166.6 | 3.41 | 66.1 | 0.055 | 30.9 | 0.27 | -120.4 |
| 2.400 | 0.71 | -174.5 | 3.13 | 60.1 | 0.056 | 29.9 | 0.28 | -125.6 |
| 2.500 | 0.71 | -178.5 | 3.00 | 57.1 | 0.056 | 29.4 | 0.29 | -129.1 |
| 3.000 | 0.73 | 164.9 | 2.47 | 43.9 | 0.057 | 30.8 | 0.32 | -140.6 |
| 3.500 | 0.75 | 151.1 | 2.07 | 32.5 | 0.059 | 34.3 | 0.35 | -150.6 |
| 4.000 | 0.77 | 139.4 | 1.80 | 22.1 | 0.067 | 36.7 | 0.40 | -158.2 |
| 4.500 | 0.78 | 126.9 | 1.56 | 10.5 | 0.074 | 34.7 | 0.43 | -167.6 |
| 5.000 | 0.79 | 116.1 | 1.37 | -0.6 | 0.082 | 30.2 | 0.47 | -174 |
| 5.500 | 0.81 | 105.6 | 1.18 | -11.6 | 0.083 | 26.7 | 0.51 | 178 |
| 6.000 | 0.84 | 96.3 | 1.00 | -20.8 | 0.086 | 22.9 | 0.54 | 169.6 |

Additional S-Parameter available on CD

Total Power Dissipation

$$P_{tot} = f(T_s)$$

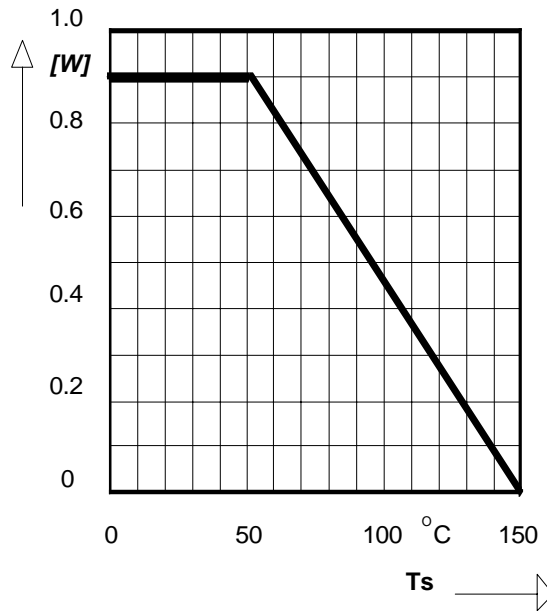

Permissible Pulse Load

$$P_{totmax}/P_{totDC} = f(t_p)$$

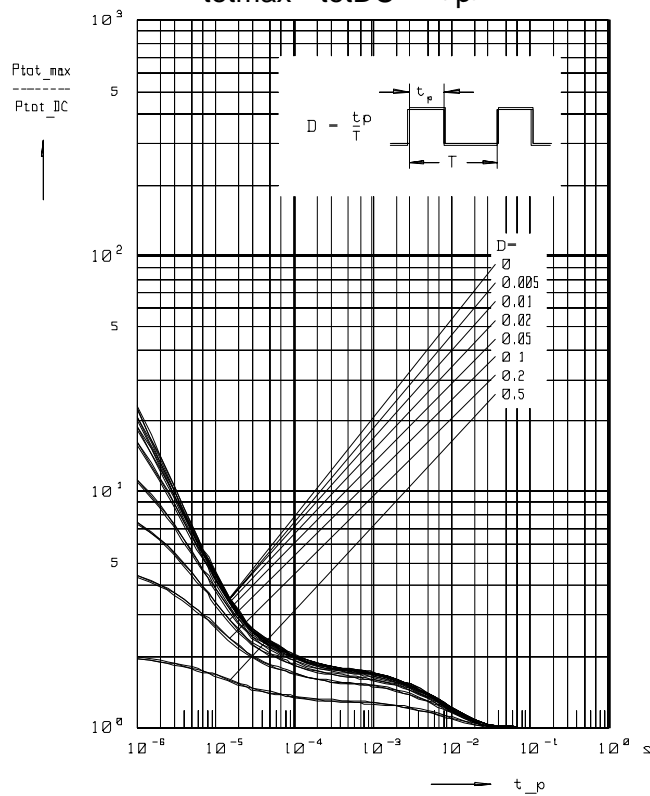

CLY2 Power GaAs-FET Matching Conditions

Definition:

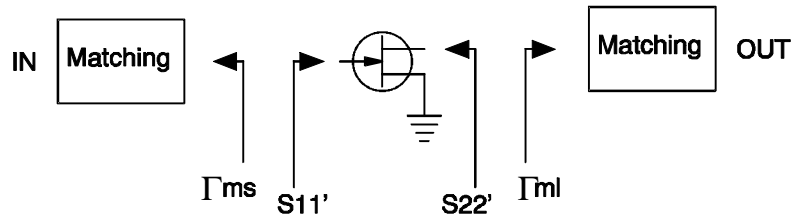

Measured Data:

| Typ | f [GHz] | V _{DS} [V] | I _D [mA] | P-1dB [dBm] | Gain [dB] | Γ _{ms} MAG | Γ _{ms} ANG | Γ _{ml} MAG | Γ _{ml} ANG |
|------|---------|---------------------|---------------------|-------------|-----------|---------------------|---------------------|---------------------|---------------------|
| CLY2 | 0.9 | 3 | 175 | 22.8 | 15.7 | 0.49 | 75 | 0.42 | -165 |
| | | 5 | 175 | 25.8 | 16.5 | 0.52 | 75 | 0.22 | -172 |
| | | 6 | 175 | 26.9 | 16.9 | 0.50 | 76 | 0.21 | -156 |
| | 1.5 | 5 | 175 | 25.8 | 16.1 | 0.68 | 106 | 0.42 | 143 |
| | | 6 | 175 | 26.9 | 16.9 | 0.76 | 113 | 0.34 | 139 |
| | | 1.8 | 2 | 175 | 19.0 | 15.0 | 0.75 | 130 | 0.52 |
| | 3 | | 175 | 22.8 | 15.4 | 0.70 | 125 | 0.45 | -172 |
| | 4 | | 175 | 24.5 | 15.6 | 0.75 | 131 | 0.41 | 166 |
| | 5 | | 175 | 25.8 | 15.7 | 0.72 | 131 | 0.38 | 163 |
| | 2.4 | 6 | 175 | 26.8 | 16.0 | 0.72 | 135 | 0.35 | 155 |
| | | 3 | 175 | 21.5 | 13.0 | 0.70 | 158 | 0.46 | -179 |
| | | 5 | 175 | 26.1 | 13.0 | 0.67 | 152 | 0.36 | -178 |

Note: Gain is small signal gain @ Γ_{ms} and Γ_{ml}