

DATASHEET

Electrical & Mechanical Specification

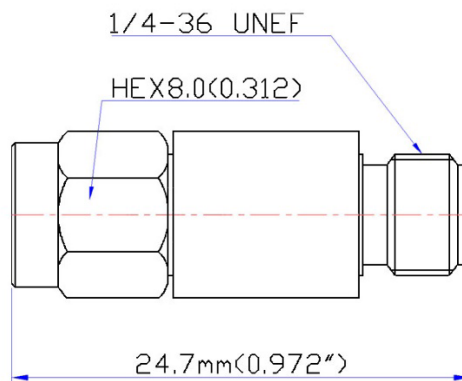

Frequency range	dc – 12.4 GHz
Attenuation	10 dB (±0.7 max.)
Power handling	2 W (bidirectional)
VSWR	1.30 (max.)
Impedance	50 Ω
Connectors	SMA male / female
Body material	Stainless steel
Body finish	Passivated
Center contact	Brass, BeCu / Gold plating
Insulator	PTFE



Attenuation & Return Loss Vs. Frequency

