

**DATASHEET**

**Electrical & Mechanical Specification**

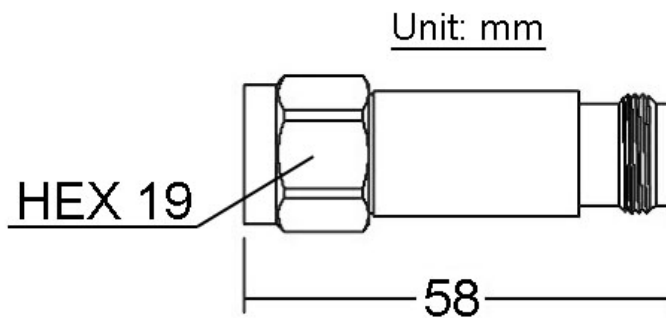

<b>Frequency range</b>	dc - 3 GHz
<b>Attenuation</b>	10 dB ( $\pm 0.6$ )
<b>Power handling</b>	2 W (bidirectional)
<b>VSWR</b>	1.22 (max.)
<b>Impedance</b>	50 $\Omega$
<b>Connectors</b>	N plug / jack
<b>Body material</b>	Brass
<b>Body finish</b>	Nickel plated
<b>Center contact</b>	Brass, BeCu / Gold plating
<b>Insulator</b>	PTFE



**Attenuation & Return Loss Vs. Frequency**

