

PRODUCT DATA SHEET

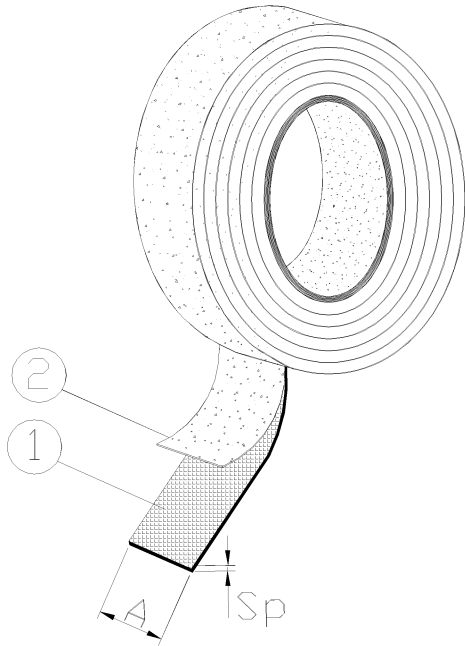

A SPECIFICATIONS

- 1- Self agglomerating EPR tape
- 2- Removable PE protection film
- Temperature resistance -40C° + 130C°.
- Waterproof.
- UV proof.
- Ozone proof.
- Hardness: 50 Shore A
- Tensile strength: 3.0 MPa
- Dielectric Breakdown: >30 KV/mm (ASTM D 149)
- Volume Resistivity : >10¹⁵ Ohm.cm (ASTM D257)
- Shelf life is 5 year, but recommended within 1 year.
- Elongation: 1000%
- Product approved to EDF HN 26-S-04 meets UTE C 33-011 specifications.

B INSTALLATION

Remove protective film and wrap the tape overlapping twice, pulling it strongly.

C DELIVERY MODALITIES

Tape is packed in single transparent PE bag
 Packing in boxes.
 Label indicating: product code, article, quantity, production batch, FIMO logo and picture.
 (Customer code on request).

D FEATURES AND BENEFIT

Excellent electrical properties, with high degree of stability.
 Rapid amalgamation of the tape when applied under tension.
 Provides void free homogeneous wrapping, without the need for heat or pressure.
 Compatible with a wide range of rubbers and plastics.
 The tape has a removable plastic film interleaf.
 Excellent resistant to water and ozone.
 Will remove cleanly from most surfaces when cut.

Connectors size	n° of roll-up connectors for NEP 19	n° of roll-up connectors for NEP 38
1/2" a/to 7/8"	6	12
1/2" a/to 1.1/4"	4	8
1/2" a/to 1.5/8"	2	4
1/2" a/to 1/2"	9	18
7/8" a/to 7/8"	4	8
1.1/4" a/to 1.1/4"	2	4
1.5/8" a/to 1.5/8"	1	2

CODE	ARTICLE	MEASURE	A	Sp.	OVERALL LENGHT	BAG	BOX	WEIGHT
612100 1975	NEP 19	19x0.75	19	0.75	10m	1	10	170
612100 3875	NEP 38	38x0.75	38	0.75	10m	1	10	340

RI	DATE	DR	DATE	AP	Description:
02					NEP - Ethylene-Propylen EPR tape, color black
01					
00	07/10/15	G.S.	07/10/15	A.V.	
1 ST EMISSION					
					Use: Insulation and protection of grounding contacts, connectors, parts exposed to corrosion.